

ARTICULO: 2040

Válvula de esfera de tres vías Tipo "L"

Three Way ball valve, Type "L"

Características
1. Válvula esfera tres vías paso reducido.
2. Configuración de Esfera en "L".
3. Extremos roscados según ISO 7-1 (EN 10226-1).
4. Construcción en Inox AISI 316 (CF8M).
5. Cuatro Asientos PTFE + 15 % Fibra de Vidrio. (otros materiales consultar).
6. Juntas del eje PTFE.
7. Tórica en el eje de FKM (Viton).
8. Dispositivo Anti-estático (Esfera-eje-cuerpo).
9. Sistema de bloqueo.
10. Montaje actuador directo s/ ISO 5211.
11. Eje inextinguible.
12. Presión de trabajo máxima 63 bar.
13. Temperatura de trabajo -25 °C + 180 °C.

Features
1. 3 Way reduced port ball valve.
2. "L" Ball configuration.
3. Threaded ends according to ISO 7-1 (EN 10226-1).
4. Made of AISI 316 (CF8M).
5. Four Ball seats PTFE + 15 % G.F. (please ask for other materials).
6. Stem gasket PTFE.
7. FKM (Viton) stem o'ring.
8. Anti-static device (Ball - Stem - Body).
9. Locking system.
10. Direct mounting actuator according to ISO 5211.
11. Blow-out proof stem.
12. Max. Working pressure 63 bar.
13. Working Temperature -25 °C + 180 °C.

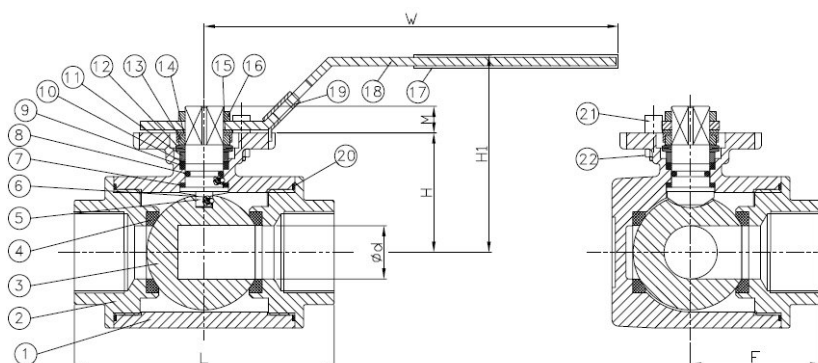

Nº	Denominación / Name	Material	Acabado Superficial / Surface Treatment	Kit Ref.
1	Cuerpo / Body	Acero Inox AISI 316 / SS 316	Granallado + Decapado / Shot blasting + Pickling	-----
2	Tapa / Cap	Acero Inox AISI 316 / SS 316	Granallado + Decapado / Shot blasting + Pickling	-----
3*	Bola / Ball	Acero Inox AISI 316 / SS 316	-----	2840
4*	Asiento / Ball Seat	Teflón + 15% FV / PTFE + 15% GF	-----	2819
5	Eje / Stem	Acero Inox AISI 316 / SS 316	-----	-----
6	Dispositivo Anti-estático / Anti-Static device	Acero Inox AISI 316 / SS 316	-----	-----
7*	Anillo Fricción / Thrust Washer	PTFE	-----	2819
8*	Tórica / O' ring	FKM (Viton)	-----	2819
9*	Empaquetadura / Stem packing	PTFE	-----	2819
10	Guarnición / Bushing	Inox. + PTFE / S.S. + PTFE	-----	-----
11	Anillo Prensa / Stem ring	Acero Inox AISI 304 / SS 304	-----	-----
12	Arandela Resorte / Spring Washer	Acero Inox AISI 301 / SS 301	-----	-----
13	Tuerca / Nut	ASTM A194-8	-----	-----

Nº	Denominación / Name	Material	Acabado Superficial / Surface Treatment	Kit Ref.
14	Antigiro / Stopper	Acero Inox AISI 304 / SS 304	-----	-----
15	Arandela / Washer	Acero Inox AISI 304 / SS 304	-----	-----
16	Tuerca Maneta / Handle Nut	Acero Inox AISI 304 / SS 304	-----	-----
17	Funda / Handle Sleeve	Vynil	-----	-----
18	Maneta / Handle	Acero Inox AISI 304 / SS 304	-----	-----
19	Bloqueo maneta / Lock device	Acero Inox AISI 304 / SS 304	-----	-----
20*	Junta / Gasket	PTFE	-----	2819
21	Tornillo Tope / Stop Bolt	Acero Inox AISI 304 / SS 304	-----	-----
22	Tuerca / Nut	ASTM A194-8	-----	-----

* Piezas que componen los Kit de Reparación / Repair Kit Parts

DIMENSIONES GENERALES / GENERAL DIMENSIONS

Ref	Medida / Size	PN	d	Dimensiones / Dimensions (mm)								Peso / Weight (Kg)
				L	H	H1	W	M	F	C x C	ISO 5211	
2040 02	1/4"	63	9.5	75	37	66	130	7	37	9 x 9	F03 / F04	0,700
2040 03	3/8"	63	11	75	37	66	130	7	37	9 x 9	F03 / F04	0,670
2040 04	1/2"	63	12	75	37	66	130	7	37	9 x 9	F03 / F04	0,630
2040 05	3/4"	63	15	85	41	72	161	7	42	11 x 11	F04 / F05	0,950
2040 06	1"	63	20	100	47	77	161	7	50	11 x 11	F04 / F05	1,400
2040 07	1 ¼"	63	25	122	56	92	203	7	61	14 x 14	F05 / F07	2,900
2040 08	1 ½"	63	32	131	60	96	203	12	65	14 x 14	F05 / F07	3,600
2040 09	2"	63	40	158	71	107	203	12	79	14 x 14	F05 / F07	6,250
2040 10	2 1/2"	63	49	178	95	135	254	14	89	17 x 17	F07 / F10	8,950

Dispositivo Antiestático / Anti-static Device

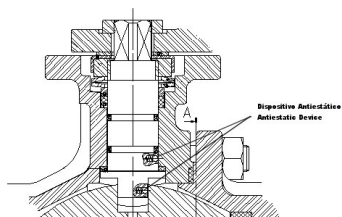

Este dispositivo garantiza la continuidad eléctrica entre esfera - eje - cuerpo, esto es de especial necesidad en fluidos inflamables. / This device ensures the electric continuity between Ball - Stem - Body, this is of special need in flammable fluids.

Detalle de la zona de Eje / Stem detail

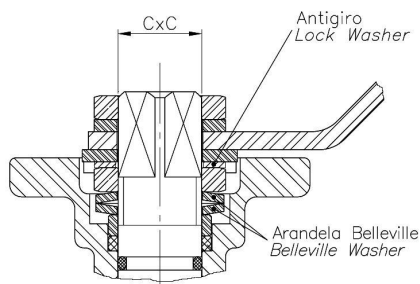

Antigiro / Lock Washer: Previene el desajuste de la tuerca del eje en elevados ciclos de maniobra / *Prevents unthreading of stem nut in high cycle automation applications.*

Arandela Belleville / Belleville Washer: Las arandelas belleville proporcionan una carga constante sobre el prensa asegurando un cierre firme en variaciones de condiciones de trabajo. / *Standard belleville washers provide constant "live load" on the stem seals, assuring a tight seal even varying service parameters.*

Configuraciones de flujo para válvula de tres vías "L - PORT" giro 90° / *Flow Patterns for "L-PORT" 3 way valves 90° turn.*

Dirección del fluido / Flow pattern (Art.2040)

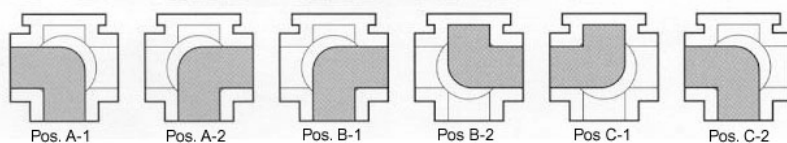

CURVA PRESIÓN TEMPERATURA / *PRESSURE TEMPERATURE RATING*

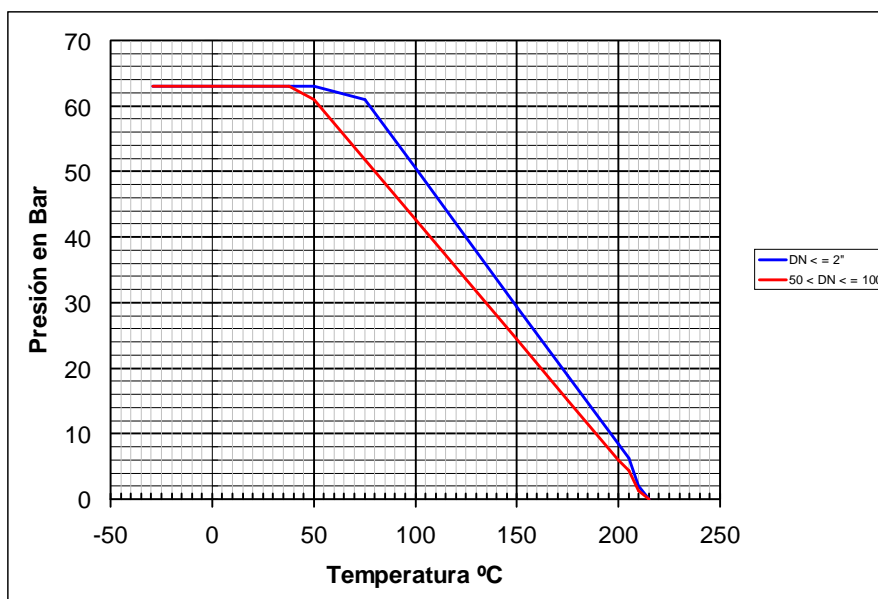

VALORES DE Kv / Kv VALUES

$Kv (m^3/h)$ = Es la cantidad de metros cúbicos por hora que pasará a través de la válvula generando una pérdida de carga de 1 bar.

$Kv (m^3/h)$ = *Flow rate of water in cubic meter per hour that will generate a pressure drop of 1 bar across the valve.*

Medida / Size	1/4"	3/8"	1/2"	3/4"	1"	1 1/4"	1 1/2"	2"	2 1/2"
m^3/h	11	11	13	15	31	39	62	103	205